

Image shown may not reflect actual engine.

SPECIFICATIONS

I-6, 4-Stroke-Cycle-Diesel

Emissions	IMO compliant
Displacement	8.82 L (538.2 cu. in.)
Rated Engine Speed	2500
Bore	112.0 mm (4.41 in.)
Stroke	149.0 mm (5.87 in.)
Aspiration	Turbocharged-Aftercooled
Governor	Electronic
Cooling System	Heat Exchanger
Weight, Net Dry (approx)	946 kg (2,086 lb)
Refill Capacity	
Cooling System	47.0 L (12.4 gal)
Lube Oil System	32.0 L (8.5 gal)
Oil Change Interval	250 hr
Caterpillar Diesel Engine Oil	10W30 or 15W40
Rotation (from flywheel end)	Counterclockwise
Flywheel and flywheel housing	SAE No. 1
Flywheel Teeth	113
Max. Exhaust Backpressure	10.0 kPa (40.2 in. water)
Fuel Consumption	111.3 L/hr (29.4 g/hr)

STANDARD ENGINE EQUIPMENT

Air Inlet System

Corrosion-resistant sea water aftercooler core, air cleaner/fumes disposal system (closed)

Control System

Electronic governor, HEUI™ fuel system, A4 electronic control module, engine-mounted 70-pin dedicated customer connector, SAE J1939 data link

Cooling System

Thermostat and housing, belt-driven centrifugal jacket water pump, gear-driven auxiliary sea water pump, expansion tank, engine-mounted heat exchanger, removal tube bundle (for sea water), engine oil cooler, auxiliary sea water lines, transmission oil cooler

Exhaust System

Watercooled exhaust manifold and wastegated turbocharger

Flywheel and Flywheel Housings

SAE No. 1 flywheel (113 teeth), SAE No. 1 flywheel housing

Fuel System

Fuel filter (RH or LH service), fuel transfer pump, fuel priming pump

Lube System

Crankcase breather, oil filter (front center service), oil filler (RH or LH service), oil level gauge (RH or LH service), oil pan, oil pan drain (RH or LH service), lubricating oil, gear-driven engine oil pump

Mounting System

Front support (adjustable height)

Protection System

Electronic overspeed shutoff

General

Torsional vibration damper and guard, lifting eyes, literature, variable engine wiring, RH or LH service options

ISO Certification

Factory-designed systems built at Caterpillar ISO 9001:2000 certified facilities

MARINE ENGINE PERFORMANCE

Preliminary

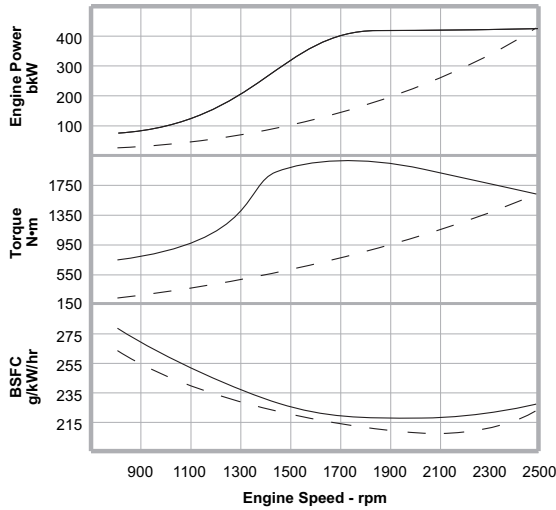

Metric Maximum Power ———
Prop Demand - - - - **423 bkW**

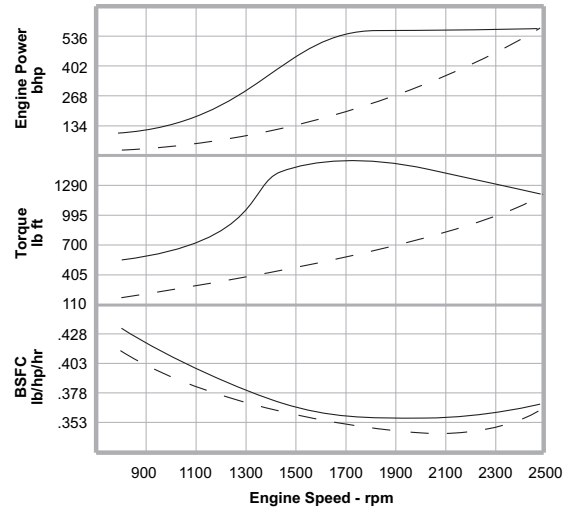

English Maximum Power ———
Prop Demand - - - - **567 bhp**

	Engine Speed rpm	Rated Engine Power bkW	Rated Engine Torque N·m	BSFC g/kWh	Fuel Rate L/hr
Maximum Power Data	2500	423.0	1616	226.0	112.4
	2400	423.0	1683	221.6	110.2
	2300	423.0	1756	218.6	108.6
	2200	423.0	1836	217.3	108.3
	2100	423.0	1924	216.6	107.9
	2000	423.0	2020	217.5	108.3
	1900	423.0	2126	219.6	109.4
	1800	401.1	2128	217.2	102.6
	1700	379.2	2130	216.6	96.5
	1600	357.1	2131	218.1	91.6
	1500	313.5	1996	221.5	81.8
1200	125.6	999	249.2	36.7	
1000	97.4	930	258.2	29.5	
800	67.5	806	278.2	22.0	
Prop Demand Data	2500	423.0	1616	223.9	111.3
	2400	375.8	1495	217.6	96.1
	2300	336.0	1395	214.3	84.8
	2200	298.5	1296	211.4	74.2
	2100	262.0	1191	209.2	64.4
	2000	226.4	1081	209.5	53.0
	1900	197.6	993	209.7	48.8
	1800	168.7	895	212.2	42.0
	1700	143.5	806	215.8	36.3
	1600	121.8	727	220.4	31.4
	1400	81.2	554	228.1	22.0
1200	52.4	417	235.3	14.4	
1000	31.7	303	243.7	9.1	
800	17.6	210	262.1	5.3	

	Engine Speed rpm	Rated Engine Power bhp	Rated Engine Torque lb ft	BSFC lb/hp/hr	Fuel Rate gal/hr
Maximum Power Data	2500	567.3	1191.8	.372	29.7
	2400	567.3	1241.5	.364	29.1
	2300	567.3	1295.2	.359	28.7
	2200	567.2	1353.9	.357	28.6
	2100	567.2	1418.7	.356	28.5
	2000	567.2	1489.6	.358	28.6
	1900	567.2	1568.1	.361	28.9
	1800	537.8	1569.3	.357	27.1
	1700	508.5	1571.1	.356	25.5
	1600	478.9	1571.8	.359	24.2
	1500	420.4	1472.1	.364	21.6
1200	168.5	736.5	.410	9.7	
1000	130.6	685.6	.425	7.8	
800	90.5	594.1	.457	5.8	
Prop Demand Data	2500	567	1192	.368	29.4
	2400	504	1103	.358	25.4
	2300	451	1029	.352	22.4
	2200	400	956	.348	19.6
	2100	351	879	.344	17.0
	2000	304	797	.344	14.7
	1900	265	732	.345	12.9
	1800	226	660	.349	11.1
	1700	192	595	.355	9.6
	1600	163	536	.362	8.3
	1400	109	409	.375	5.8
1200	70	307	.387	3.8	
1000	43	223	.401	2.4	
800	24	155	.431	1.4	

DIMENSIONS

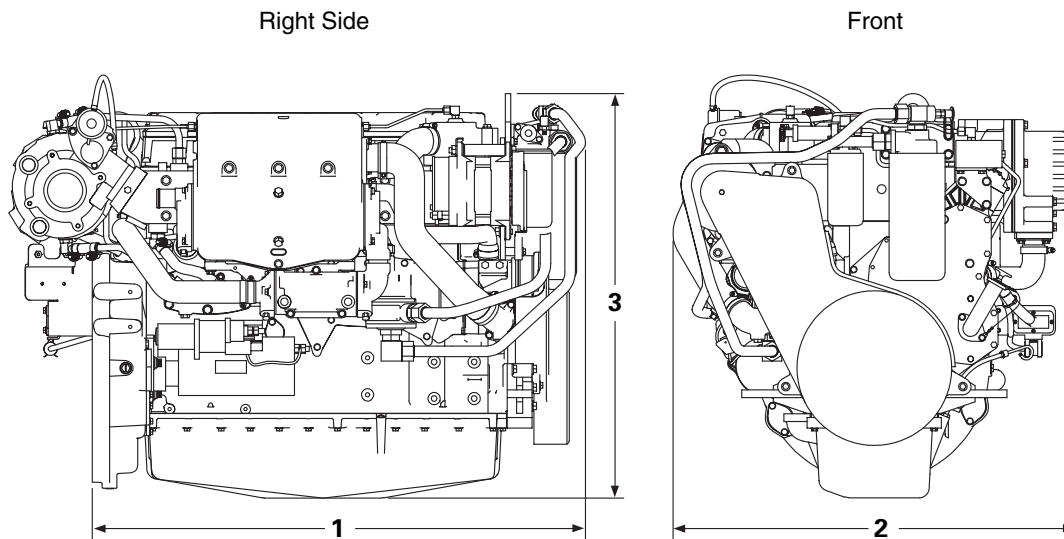

Engine Dimensions		
(1) Length to Flywheel Housing	1198.7 mm	47.19 in.
(2) Width	974 mm	38.3 in.
(3) Height	982.8 mm	38.69 in.
Weight, Net Dry (approx)	946 kg	2,086 lb

Note: Do not use for installation design.

RATING DEFINITIONS AND CONDITIONS

E Rating (High Performance)

% Load Factor: up to 30

% Time at Rated RPM: up to 8

Typical Time at Full Load: 1/2 hour out of 6

Typical Hour/Year: 250 to 1000

Typical Applications: For vessels operating at rated load and rated speed up to 8% of the time (up to 30% load factor). Typical applications could include but are not limited to vessels such as pleasure craft, harbor patrol boats, harbor master boats, some fishing or patrol boats. Typical operation ranges from 250 to 1000 hours per year.

Power at declared engine speed is in accordance with ISO3046-1:2002E. Caterpillar maintains ISO9001:1994/QS-9000 approved engine test facilities to assure accurate calibration of test equipment. Electronically controlled engines are set at the factory at the advertised power corrected to standard ambient conditions. The published fuel consumption rates are in accordance with ISO3046-1.

Fuel rates are based on fuel oil of 35° API [16°C (60°F)] gravity having an LHV of 42 780 kJ/kg (18,390 Btu/lb) when used at 29°C (85°F) and weighing 838.9 g/L (7.001 lb/U.S. gal). Additional ratings may be available for specific customer requirements. Consult your Caterpillar representative for additional information.

Performance data is calculated in accordance with tolerances and conditions stated in this specification sheet and is only intended for purposes of comparison with other manufacturers' engines. Actual engine performance may vary according to the particular application of the engine and operating conditions beyond Caterpillar's control.

Power produced at the flywheel will be within standard tolerances up to 50°C (122°F) combustion air temperature measured at the air cleaner inlet, and fuel temperature up to 52°C (125°F) measured at the fuel filter base. Power rated in accordance with NMMA procedure as crankshaft power. Reduce crankshaft power by 3% for propeller shaft power.